

MATERIAL PROCESSING GUIDE

Pocket Reference

Complet[®]
COMPOSITE PELLETS

Introduction to Long Fiber

Material & Machine Preparation

Machine Operation

Problem Solving

Typical Processing Guidelines

The logo for PlastiComp features a stylized red graphic of a curved, segmented shape above the company name. The name "PlastiComp" is written in a bold, red, sans-serif font.

PlastiComp

Introduction to Long Fiber

THIS GUIDE: The PlastiComp™ Material Processing Guide is intended to be a useful resource for people who have the responsibility to set up and/or operate injection molding machines producing parts made from long fiber reinforced materials. In preparing this manufacturing pocket reference, industry specialists with decades of experience have focused on delivering the most helpful information they have gathered regarding the molding of long fiber reinforced thermoplastic materials. We recognize that there are a variety of processing manuals available but we've learned that there is widespread interest in a compact, convenient and easy to use document that can be carried in a pocket, briefcase or posted at a molding machine location.

LONG FIBER REINFORCED THERMOPLASTIC MATERIALS: Simply stated, reinforced thermoplastic materials identified as being "long fiber" are those in which the individual reinforcing fibers are of uniform length and are in parallel alignment with each other. In other words, the individual reinforcing fibers are aligned with respect to each other, and are exactly as long (usually 11mm) as the pellet. In contrast, short fiber reinforced thermoplastic materials contain reinforcing fibers of various short lengths that are randomly orientated in the resin/pellet.

ADVANTAGES OF LONG FIBER REINFORCED THERMOPLASTIC MATERIALS: Injection molded parts manufactured with long fiber reinforced thermoplastic materials can deliver predictable superior mechanical performance compared to short fiber reinforced thermoplastic materials. Product engineers can literally design the performance characteristics (tensile and impact strength, dimensional stability, thermal stability, etc.) of a finished part, knowing that a long fiber reinforced material can be engineered to deliver the specific desired mechanical performance to meet the application needs.

QUALITY RESULTS REQUIRE SKILL AND ATTENTION: The production of high-quality injection molded parts requires knowledge of the molding process, skill and careful attention to startup details, and consistent management of the process throughout the entire production run. The resulting performance properties of a molded part can be degraded as a result of inadequate preparation and monitoring of all elements of the molding process. With good preparation and process management, quality parts will result and rejects and waste will be reduced.

Material & Machine Preparation

MATERIAL AND MACHINE PREPARATION: Proper material storage, handling, drying and machine feed conditions must be maintained in order to ensure consistency in the manufacturing of high quality injection molded parts.

MATERIAL STORAGE: Always store Complēt® materials in a warm, dry location. Cold temperatures encourage condensation on packaging and pellets while warm, moist conditions cause polymer moisture absorption. Internal (for hygroscopic material) and external (for nonhygroscopic material) pellet moisture levels are a common cause of both process and part quality problems. Further, high moisture content in the polymer can degrade the performance properties of certain materials.

MATERIAL DRYING: Proper drying of both hygroscopic and non-hygroscopic materials is essential for molding quality parts. Drying time and temperature will vary depending upon the specific polymer being used. Please refer to the "Process Foldout" for specific drying time and temperature for all Complēt® materials. Do not attempt to dry the material in an air circulating oven.

MATERIAL HANDLING: A pneumatic material handling system has proven to be the best method for safe transfer of injection molding materials. Hose and auger systems can also be used but have disadvantages of floor space requirements and interface to hoppers and dryers. Whether using a pneumatic or auger system, smooth inner walls on hoppers and transfer pipes, hoses and tubes are essential to minimize pellet damage.

**NEED HELP WITH PROBLEM
SOLVING QUESTIONS?**

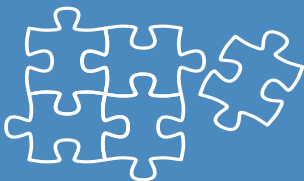

**PLEASE VISIT OUR ON-LINE RESOURCES.
WWW.PLASTICOMP/PROBLEMSOLVING**

Machine Operations

MACHINE OPERATION: The overall objective during the molding of Complēt® long fiber reinforced materials is to get the pellet from the hopper to the finished molded part with minimal reduction of the original fiber length. The many performance benefits of long fiber reinforced material can be reduced or lost through inattention to a careful machine setup and closely managed manufacturing process. Proper equipment settings, smooth flow and watchful process management are essential to the production of a molded part that features a perfect surface, correct color, dimensional accuracy and conforms in every way to customer blueprint specifications.

PROPER SETUP

- Take time to study the recommended machine settings
- Establish a process monitoring discipline
- Confirm all machine parameters before starting the run

THE RIGHT SCREW

- General purpose metering screw – L/D ratio 18-20:1 – 40% Feed, 40% Transition, 20% Metering. Mixing screws should not be used.
[See Figure 1]
- Low compression Ratio – 2:1 to 3:1
- Deep flights – Metering zone 3.5 mm. Feed zone 7.5 mm
- Free flowing check-ring – three-piece ring valve
[See Figure 2]
- Nozzle configuration should be general purpose with a minimum orifice diameter of 7/32 in. Full taper (nylon tip) design nozzles are not recommended for use with long fiber reinforced materials.
[See Figure 3]

SCREW SPEED AND BACK PRESSURE

- Slow – 20-50 rpm
- Adjust to the lower end of indicated speed range
- Adjust to low to moderate back pressure – 25-50 psi

TEMPERATURE MANAGEMENT

- Understand recommended temperature profile for the specific material being molded.
- In general, getting the pellet into the melt phase as quickly as possible, at fairly high temperature, increases success. With this approach, fibers flow more easily and move safely through the screw with minimum fiber breakage.
- Adjustments may be needed

Machine Operations

- Quickly heat the rear zone of the machine to minimize shear and fiber damage
- Temperature Zones
 - Rear – Lowest
 - Middle – Slightly higher than the rear zone
 - Front – Slightly higher than the middle zone
 - Nozzle – Typically same temp. as the front zoneA flat or reverse profile is often used to enhance fiber length in the molded part.

INJECTION PHASE SPEED AND PRESSURE

- Adjust to the lower end of the indicated speed range – 2-3 in/sec
- Adjust to the lower end of the indicated pressure range – Medium to Maximum
- Cushion: 1/4 in

USE PREFERRED NOZZLE AND GATE AND RUNNERS

- Gates, spurs and runners will be dependent upon part and mold configuration. Full round runner systems (1/4 in dia) are preferred but trapezoidal designs (1.25 x depth of runner) are acceptable. Gates should be as large as practical depending upon part size and configuration. Minimum 1/4 in x 1/8 in Land Length 1/2 in Gate Depth.
- Molds should be vented wherever possible, at parting lines, runners, ejector pins, etc. (.002 in x .500 in typical).
- Regrind up to 5% may be used without impacting performance of the finished part.

MOLDING CYCLE INTERRUPTIONS

- It is critical that heated material remain in motion. If, for any reason, the molding cycle is interrupted for more than a few minutes, you must reduce the barrel cylinder temperatures while the machine is idle, or, purge the machine as described below.

MACHINE SHUT DOWN PROCESS

- When a machine is to be shut down from molding Complēt® materials, it is essential that the machine be purged with polypropylene or polyethylene. After the heating cylinder has completely cooled you may shut down the machine.

Illustrations

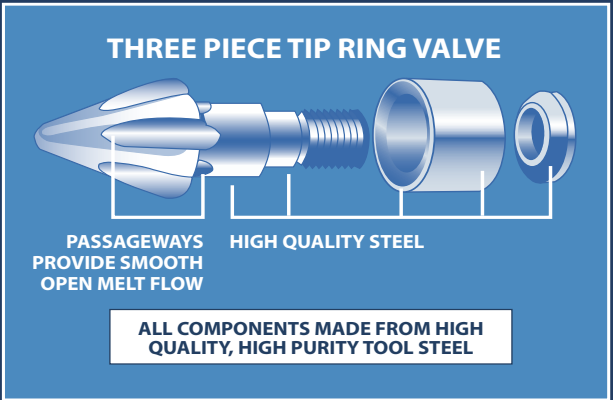

FIGURE 2

Free flowing check-ring – three-piece ring valve

Disassembled view of a three piece screw tip valve assembly showing its component parts.

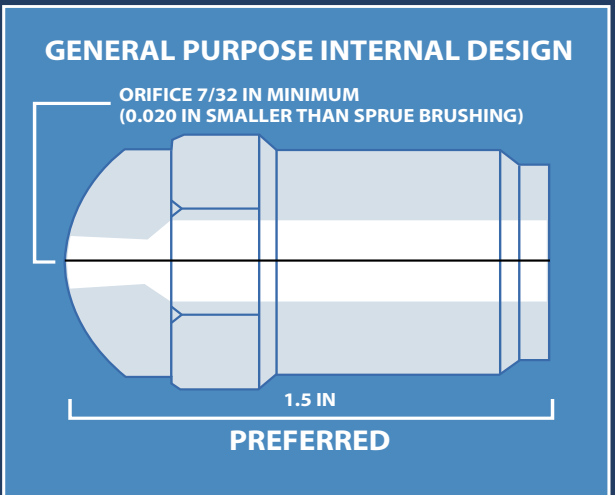

FIGURE 3

Nozzle configuration should be general purpose with a minimum orifice diameter of $7/32$ in.

Illustrations

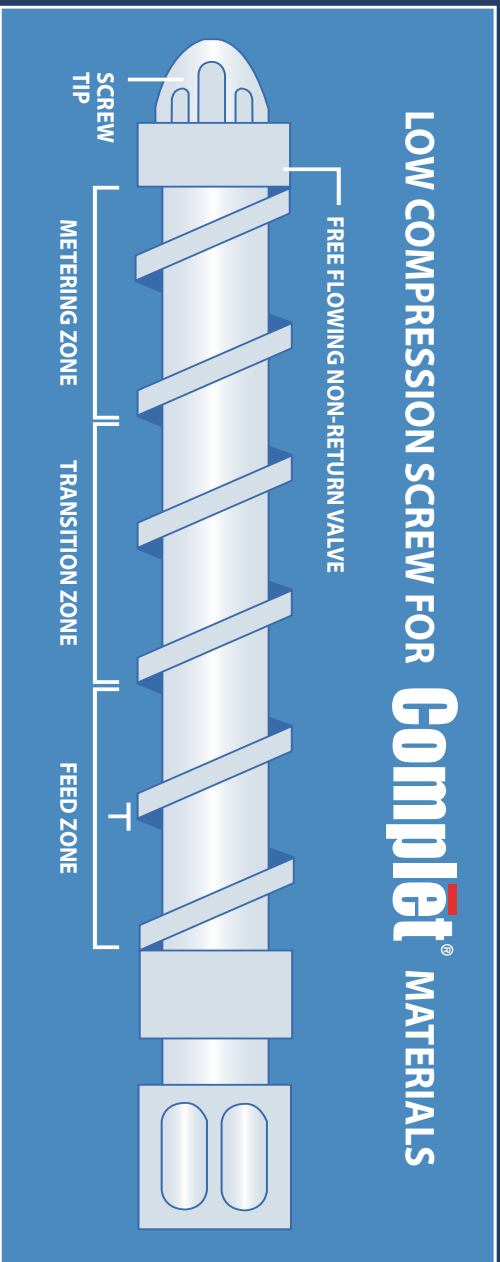

FIGURE 3

General purpose metering screw – L/D ratio 18-20:1 – 40%

Feed, 40% Transition, 20% Metering: Mixing screws should not be used.

Typical Processing Guidelines

Polymer Type	Nylon 66	Nylon 6	PP	PU	PPS
Processing Temperatures	°F/°C	°F/°C	°F/°C	°F/°C	°F/°C
Rear Zone	540 - 570 (282 - 299)	500 - 530 (260 - 277)	390 - 410 (199 - 210)	390 - 410 (199 - 210)	390 - 410 (199 - 210)
Center Zone	550 - 580 (288 - 304)	510 - 540 (266 - 282)	400 - 420 (204 - 216)	400 - 420 (204 - 216)	400 - 420 (204 - 216)
Front Zone	560 - 590 (293 - 304)	520 - 550 (271 - 388)	410 - 430 (210 - 221)	410 - 430 (210 - 221)	410 - 430 (210 - 221)
Nozzle	550 - 580 (288 - 304)	520 - 550 (271 - 388)	400 - 420 (204 - 216)	400 - 420 (204 - 216)	400 - 420 (204 - 216)
Melt	560 - 590 (293 - 304)	520 - 550 (271 - 388)	410 - 430 (210 - 221)	410 - 430 (210 - 221)	410 - 430 (210 - 221)
Mold	200 (93)	200 (93)	150 (66)	150 (66)	150 (66)
Processing Variables					
Injection Speed	~2-3 in/s (51-76 mm)	~2-3 in/s (51-76 mm)	~2-3 in/s (51-76 mm)	~2-3 in/s (51-76 mm)	~2-3 in/s (51-76 mm)
Injection Pressure	Medium to Maximum	Medium to Maximum	Medium to Maximum	Medium to Maximum	Medium to Maximum
Back Pressure	25 -50 psi	25 -50 psi	25 -50 psi	25 -50 psi	25 -50 psi
Screw Speed	30 -50 rpm	30 -50 rpm	30 -50 rpm	30 -50 rpm	30 -50 rpm
Cushion	1/4 in (6.4 mm)	1/4 in (6.4 mm)	1/4 in (6.4 mm)	1/4 in (6.4 mm)	1/4 in (6.4 mm)

Polymer Type	Nylon 66	Nylon 6	PP	PU	PPS
Drying Conditions					
Temperature	175°F (80°C)	175°F (80°C)	200°F (93°C)	175°F (80°C)	270°F (132°C)
Time	4 Hours	4 Hours	2 Hours	4 Hours	4 Hours
Moisture Content	0.18%	0.18%	N/A	0.02%	0.02%

Please Note:

1. Processing temperatures shown are generally for 30-60% fiber content materials. Lower temperatures should be used for lower fiber content.
2. Most all Complet® materials will suffer discoloration if overdried.
3. Complet® Polyurethane materials require special drying considerations. Contact PlastiComp™ technical support for specifics.

NOTICE: The information contained in this guide is accurate to the best of our knowledge at the time of publication; however, we assume no liability whatsoever for the accuracy and completeness of such information. Further, the information and techniques presented in this guide are often simplifications and, therefore, should not be relied upon for any particular use. Independent analysis and prototype testing under the harshest conditions likely to be encountered must be conducted to verify suitability of materials and satisfactory part performance. We make no representation or recommendation regarding suitability of processes or materials for any particular use. It is your responsibility to determine the suitability of processes and materials for your intended use and to ensure compliance with applicable health and safety standards. Material data and values included in this guide are based on sources deemed to be reliable and are believed to be representative. However, they are not intended for use in establishing values for specification purposes. Colorants or other additives may cause significant variation in data values. You should adhere to the manufacturer's or supplier's instructions for use and handling of materials. It is your responsibility to determine whether your use of any materials infringes any patent. To the extent that any hazards may have been mentioned in this guide, we neither suggest nor guarantee that such hazards are the only ones that exist. For further information, please refer to our website and/or call the numbers provided in this guide.

Complet[®]

COMPOSITE PELLETS

**PlastiComp[™], LLC
Global Headquarters &
Technical Development Center
110 Galewski Drive
Winona, Minnesota 55987 U.S.A.
Phone: 507.454.4334
Fax: 507.452.5642
Toll Free: 1.888.454.4334
www.plasticomp.com**

**PlastiComp[™], LLC
Compounding Facility
25 McConnon Drive
Winona, Minnesota 55987 U.S.A.
Phone: 507.474.0939
Fax: 507.474.0949
Toll Free: 1.888.454.4334**

**PlastiComp Europe GmbH
Technical Sales, Europe
P.O. Box 138
4650 AC Steenberg
The Netherlands
Phone: +31 611.252522
Fax: +31 84.754.2449
Toll Free: 1.888.454.4334
www.plasticomp.de**

This PlastiComp[™] Material Processing Guide is printed with permanent inks on synthetic paper that loves abuse. It is strong, durable, tear-resistant and wipes clean. Carry it in your pocket or hang it on your machine. It should last a long time. Let us know if you would like additional copies of the Guide.